1. Revisions	2
2. Introduction	3
3. Intended Use	3
4. Safety Instructions	3
4.1 Operational safety	3
5. Installation, Commissioning and Operation	4
5.1 Return	4
5.2 Contact	4
6. Identification	5
6.1 Reception	5
6.2 Scope of Delivery	6
7. Possible Applications	7
7.1 Bulk Water Sensor according EI 1592 in Pipe Section	7
7.2 SLUGGUARD® in Water Sump of Filter Water Separator	7
7.3 SLUGGUARD® Below Water Sump on Filter Vessels	8
7.4 Options and their Accessories	8
7.5 Ball Valve for SLUGGUARD®	9
8. General Safety and User Instructions	10
8.1 Safety	10
8.2 Installation for Various Applications	10
8.3 Connection	11
8.4 Electrical Connection in Explosion Hazard Areas	11
8.5 Explosive Gas Atmospheres Zone 0 and Zone 1	12
8.6 Isolating Barrier for SLUGGUARD®	13
8.7 Relay Outputs of Barrier	13
9. Cleaning, Maintenance and Repair	14
9.1 Disposal	14
10. Technical Data	15
11. ATEX Approval	16
12. EU Declaration of Conformity	18

1. Revisions

Revision	Revision Details	Received and entered by	Date
0	Standard Manual	Matthias Aden	23/07/2019
3	ATEX Certificate on Page 16	Matthias Aden	15/01/2020
5	EU Declaration of Conformity on Page 18	Stefan Graf	14/08/2020
6	General Adjustment	Stefan Graf	13/07/2021
7	ATEX dust included / IP67 page 12	Matthias Aden	01/12/2021

Notes on Safety Icons and Symbols



Warning!

This symbol alerts you to hazards. They can cause serious damage to the instrument or to persons if ignored.



Caution!

This symbol alerts you to possible faults which could arise from incorrect operation. They could cause damage to the instrument if ignored.



Note!

This symbol indicates important items of information.

2. Introduction

For secure and error-free operation of the device, these operating instructions must be read with care before commissioning and kept at a site well accessible for the operator/s.

Should further questions arise after the lecture of these operating instructions please do not hesitate to contact our sales representatives.

3. Intended Use

The SLUGGUARD® bulk water sensor is designed for the detection of bulk quantity of free water in running aviation fuel or for the distinction of media (fuel / water) in low points of filter water separators or in drain points of filter vessels. The manufacturer is not liable for damages caused by improper or non-intended use of the device.

4. Safety Instructions

This manual provides operation and routine maintenance instructions for the FAUDI Aviation SLUGGUARD®. Read this manual and ensure that you fully understand its content before you attempt to install, use or maintain the SLUGGUARD®.

Work on electrical equipment is to be conducted by trained specialists only, according to valid regulations. Attention must be paid to the requirements of VDE 0100 when setting up high-power electrical units with nominal voltages of up to 1000V, including associated standards and stipulations.



Check the details on the type plate to ensure that the equipment is connected to the correct mains voltage.

Protect against touching dangerously high electrical voltages. Opening the equipment is strictly prohibited. The equipment is only to be used within the permitted temperature and operation ranges (see Chapter 10).

All CHANGES of the SLUGGUARD® with parts which are not specified or approved by FAUDI Aviation GmbH, as well as repair and service with unspecified parts will result in loss of the CE conformity and guarantee.

In case of doubt, please turn directly to FAUDI Aviation GmbH, respectively to your FAUDI Aviation Distributor or Service organization.



Danger, safety, prohibition and risk notes in this manual must be complied with under all circumstances!

4.1 Operational Safety

The SLUGGUARD® is designed and tested according to the state of the art and left the factory in perfect functioning order. Relevant regulations and European standards have been met.

As the user, you are responsible for complying with the following safety conditions:

- Installation instructions
- Local prevailing standards and regulations

5. Installation, Commissioning and Operation

For cabling and mechanical setup of the SLUGGUARD® please refer to the training documents (Certified Installer Training).

Before commissioning of the entire measuring point, check that all connections are installed correctly. Ensure that electrical cables are not damaged. Do not operate damaged products and secure them against unintentional commissioning. Mark the damaged product as being defective.

Measuring point faults may only be rectified by authorised and specially trained personnel. If faults cannot be rectified, the products must be taken out of service and secured against unintentional commissioning.

Repairs may only be carried out by manufacturer or by a designated service organisation.

5.1 Return

If the device requires repair, please send it in cleaned condition to the appropriate sales centre. Please use the original packaging, if possible.

When sending for repair, please enclose a note with a description of the error and the application.

Please enclose the certificate of decontamination (to be found on the download section of FAUDI-Aviation-Sensor homepage).

5.2 Contact



Contact address of manufacturer:

FAUDI Aviation GmbH

Scharnhorststraße 7B

D-35260 Stadtallendorf

Tel.: +49 (6428) 44 652 570

Fax: +49 (6428) 44 652 223

Email: sensor@faudi-aviation.com

Web: www.faudi-aviation.com

6. Identification



SLUGGUARD® with LED

6.1 Reception

You should have received a device like above.

Make sure the packaging is undamaged!
Inform the supplier about damage to the packaging.
Keep the damaged packaging until the matter has been settled.

Make sure the contents are undamaged!
Inform the supplier about damage to the delivery contents. Keep the damaged products until the matter has been settled.

Check that the scope of delivery is complete and agrees with your order and the shipping.
The packaging material used to store or to transport the product must provide protection against shock and humidity. The original packaging offers the best protection. Also, keep to the approved ambient conditions (see "Technical data").

If you have any questions, please contact your supplier or your sales centre responsible.

6.2 Scope of Delivery

The following items are included in the delivery:

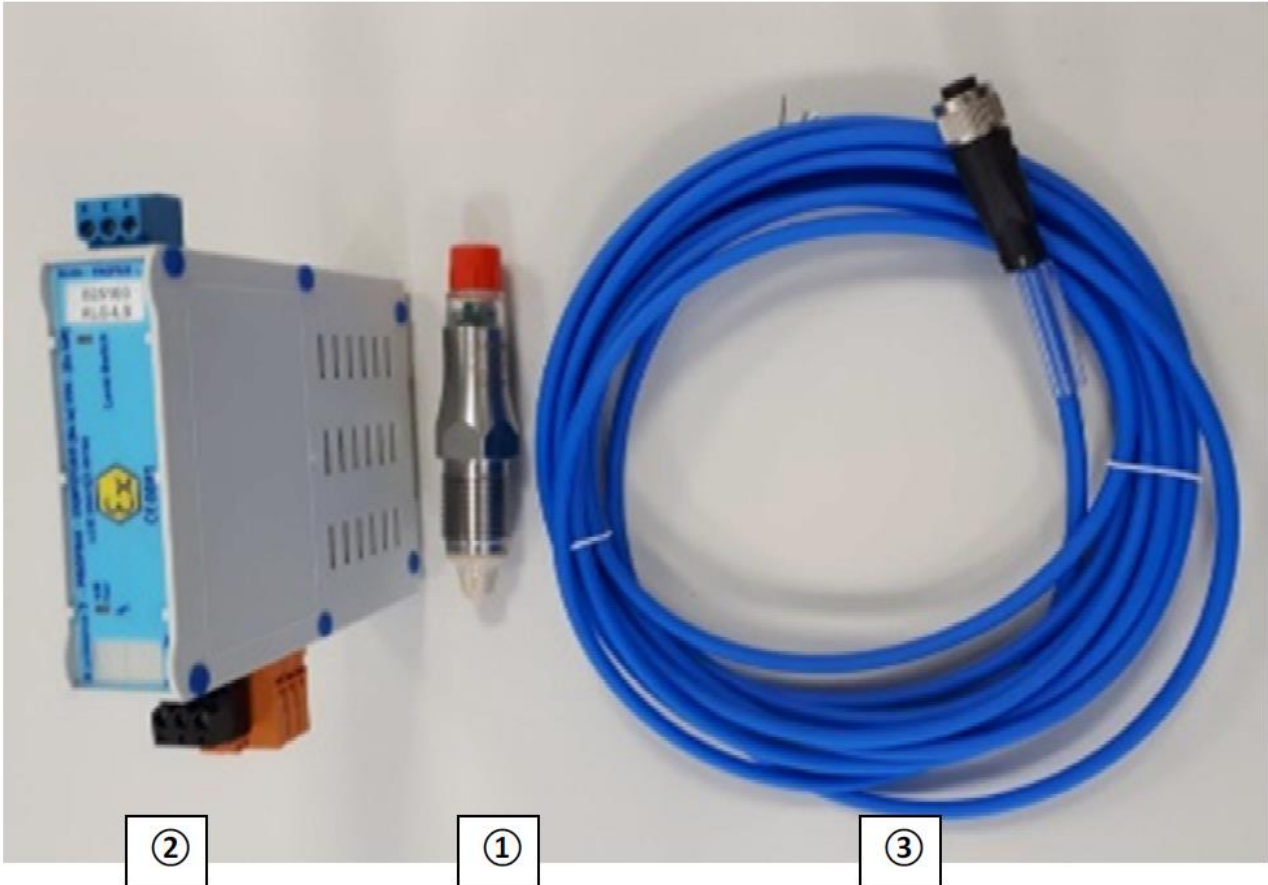

One Set comprises:

- 1 SLUGGUARD®
- 2 Dedicated barrier for hazardous area installation of SLUGGUARD® in zone 0 / 1
- 3 15m connection cable between sensor and barrier

7. Possible Applications

7.1 Bulk Water Sensor according EI 1592 in Pipe Section

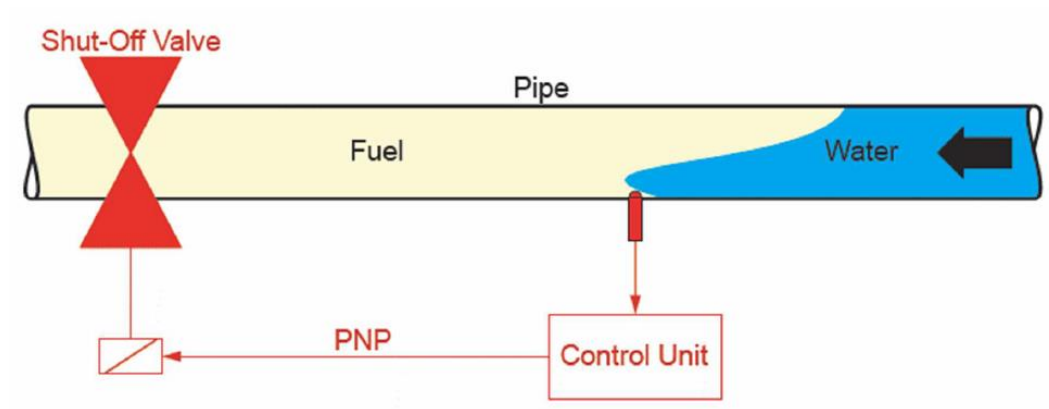

7.2 SLUGGUARD® in Water Sump of Filter Water Separator

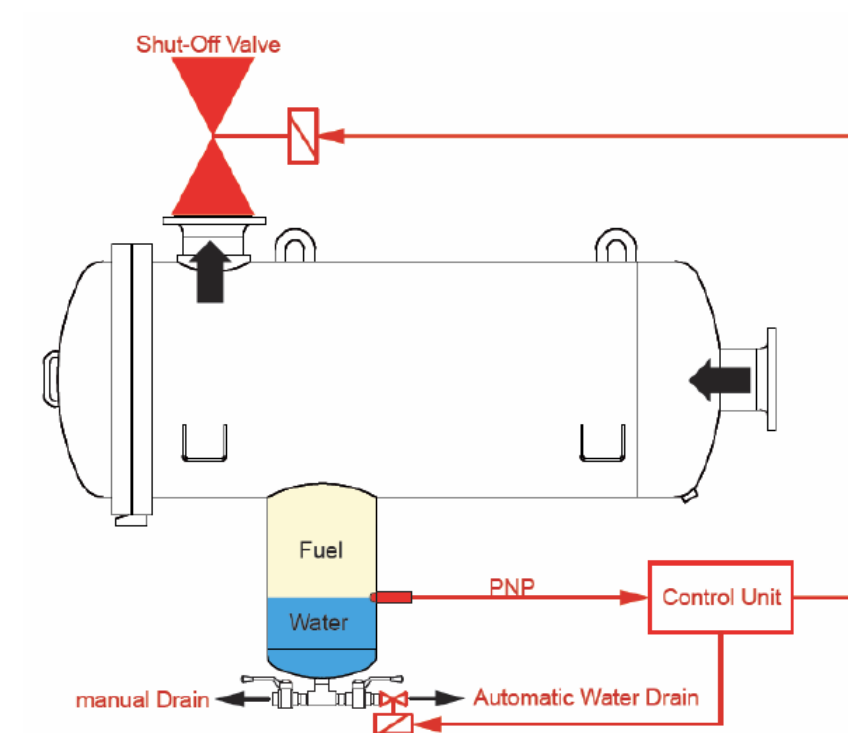

7.3 SLUGGUARD® Below Water Sump on Filter Vessels

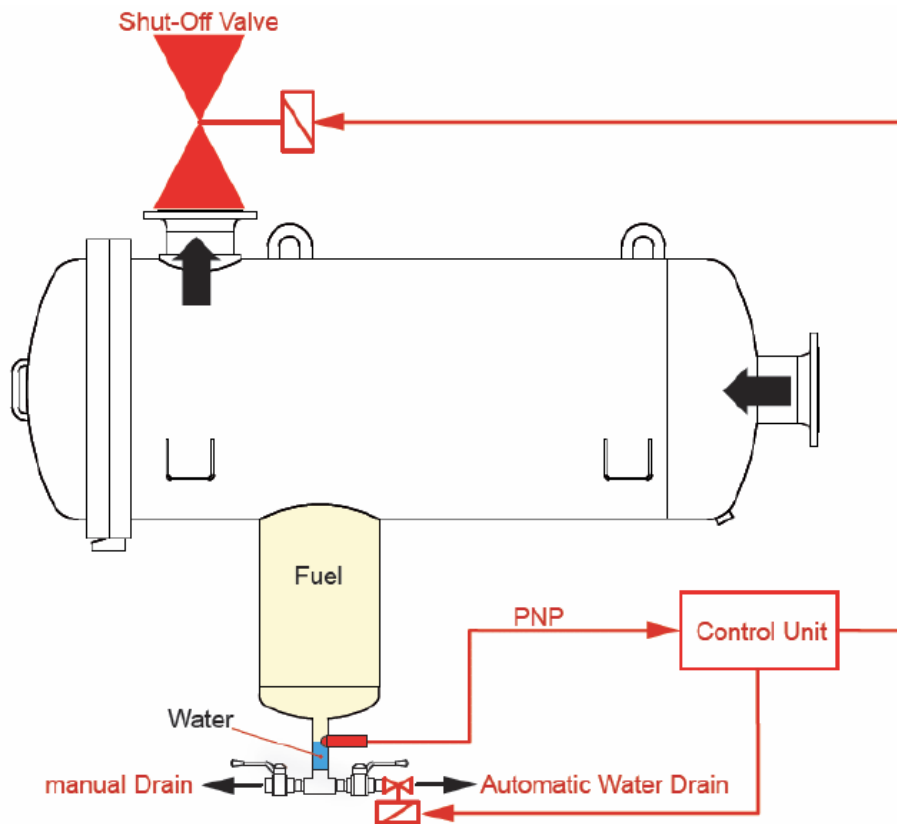

7.4 Options and their Accessories

SLUGGUARD® Stainless Steel without LED, G1/2 process connection, M12 plug connector, PNP output	Part No. 600040
SLUGGUARD® Stainless Steel with LED, G1/2 process connection, M12 plug connector, PNP output	Part No. 600001
Barrier with power supply and relays output	Part No. 600041
Connection cable with M12 connector, 15 m length	Part No. 526102
Measuring ball valve for SLUGGUARD®	Part No. 600511

7.5 Ball Valve for SLUGGUARD®

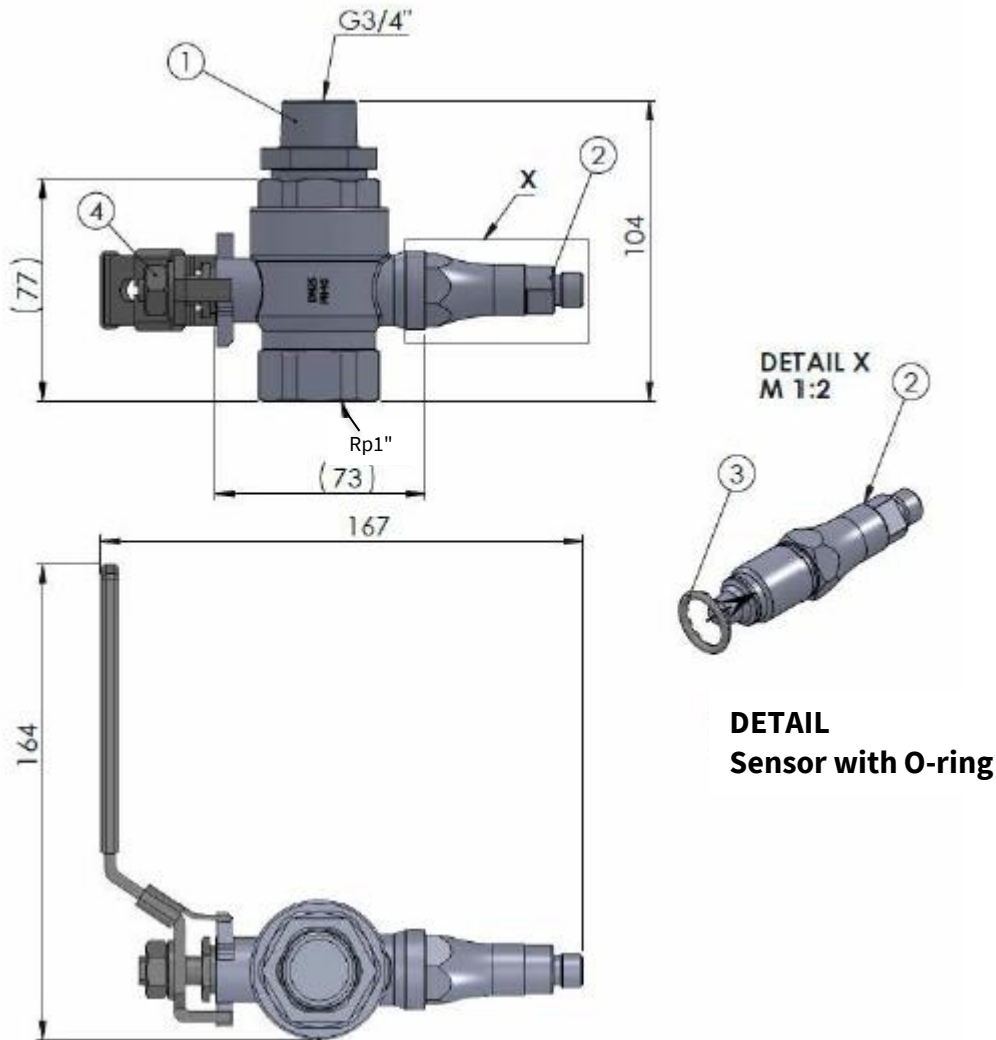

Pos	Description	Description 2	Material
1	Double nipple (not in scope of delivery)	R 1" / 3/4"	1.4571
2	SLUGGUARD®	Without LED	-
3	O-Ring 17,86x2,62		NBR
4	Ball Valve SLUGGUARD®		SS



When using the ball valve for the SLUGGUARD® – the sealing will be generated via O-ring.
No need to use Teflon tape!
Tightening torque: 20 – 30 Nm max.

8. General Safety and User Instructions

8.1 Safety

Intended use

The sensor must be used solely for the level detection of liquids in applications which are specified and approved by FAUDI Aviation GmbH.

The sensor must only be used for media against which the housing material and sensor tip are resistant.

Staff qualification

Installation and operating personnel must be qualified and instructed. This applies in particular to assembly, installation and explosion protection. Make sure that the staff has read and understood these instructions.

Technical condition

Use the sensor only when in perfect technical condition. Only use FAUDI Aviation GmbH accessories. FAUDI Aviation GmbH will accept no liability for other manufacturers' accessories.

Risk of burns from hot media

During operation the sensor housing may warm up to over 50 °C. When working with hot media provide protection against burns.

Explosion hazard areas

Ensure that safety requirements are complied with. Do not use equipment that would be exposed to hard impacts.

8.2 Installation for Various Applications

When using the SLUGGUARD® without the dedicated ball valve – use sufficient sealant material like PTFE (Teflon tape) to seal the sensor.

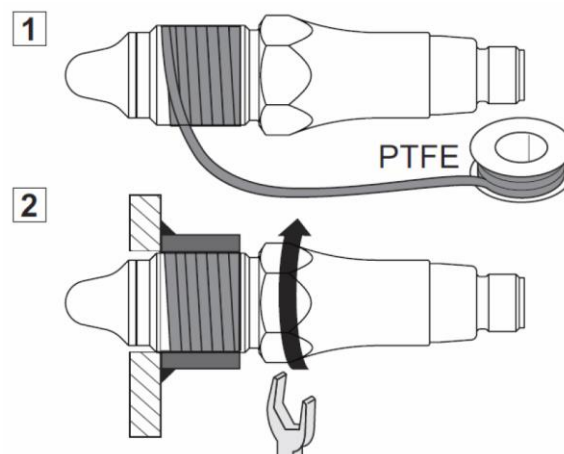

SLUGGUARD® with common G1/2 process connection:
Ensure that vessel and pipelines are free of media.

Seal thread on sensor with Teflon tape (PTFE).
Screw in SLUGGUARD®. Tightening torque G 1/2: 30 Nm max.

8.3 Connection

A voltage supply of 12 V to 30 V DC should be provided
1) Switch off supply voltage.
2) Connect the sensor in accordance with the pin assignment.

Terminal assignment

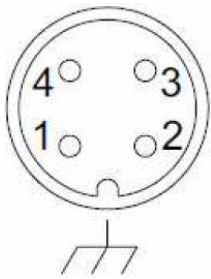

Output type	Equivalent circuit	Function	M12-A 4-pin	Cable outlet
PNP		+ Vs SW1 (NO) SW 1 (NC) GND (0 V)	1 4 2 3	Brown Black White Blue

8.4 Electrical Connection in Explosion Hazard Areas

Depending on the variant, the SLUGGUARD® is approved for most explosion hazard areas.

CAUTION!



Risk of fatal accident due to a wrongly connected sensor

In explosive gas atmospheres of zone 0 or 1, use FAUDI Aviation GmbH isolation barriers.
Use in minimum insulated cable conforming to IP67 specification.
Allow only persons trained in explosion protection to perform the installation.

8.5 Explosive Gas Atmospheres Zone 0 and Zone 1

The SLUGGUARD® can be used in explosion hazard areas of zone 0 or zone 1.
Sensors with PNP can only use FAUDI Aviation GmbH isolation barriers which are easy to install.

Approval for SLUGGUARD® with certificate number: TÜV 19 ATEX 247467 X (see Chapter 11)

The SLUGGUARD® can be used in explosion hazard areas of zone 20, 21 and 22.

Gas

ATEX II 1 G Ex ia IIC T4/T5 Ga

Dust

ATEX II 1 D Ex ta IIIC T100°C Da

Highest values for selection of barriers	Ui: 30 V DC Li: 100 mA Pi: 0,75 W
Internal capacitance:	Ci: 43 nF ¹⁾
Internal inductance:	Li: 10 µH ²⁾
Temperature class	T4: -40 < Tamb < 85 °C T5: -40 < Tamb < 74 °C
▪ Standard version	

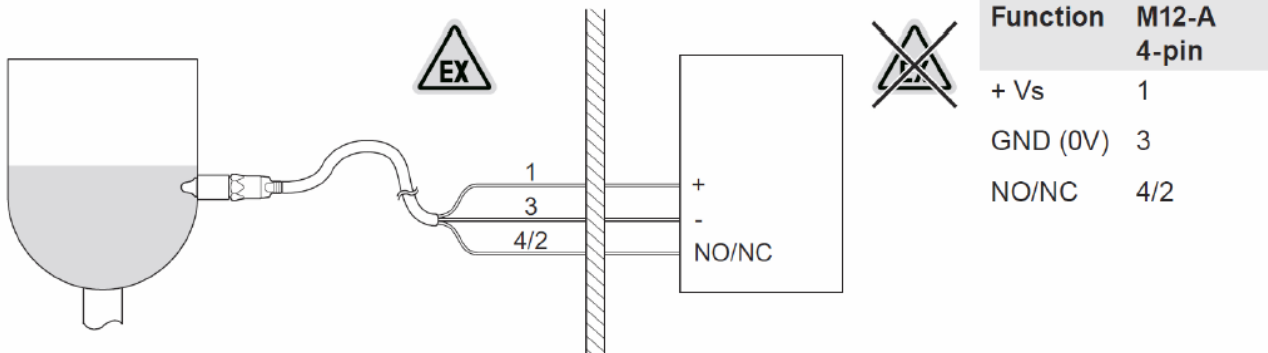

SLUGGUARD® uses a 4-wire cable. IN PNP connection – only black, brown and blue cables are in use – white is only needed for programming.

Protection class to cable accessories is IP67

8.6 Isolating Barrier for SLUGGUARD®

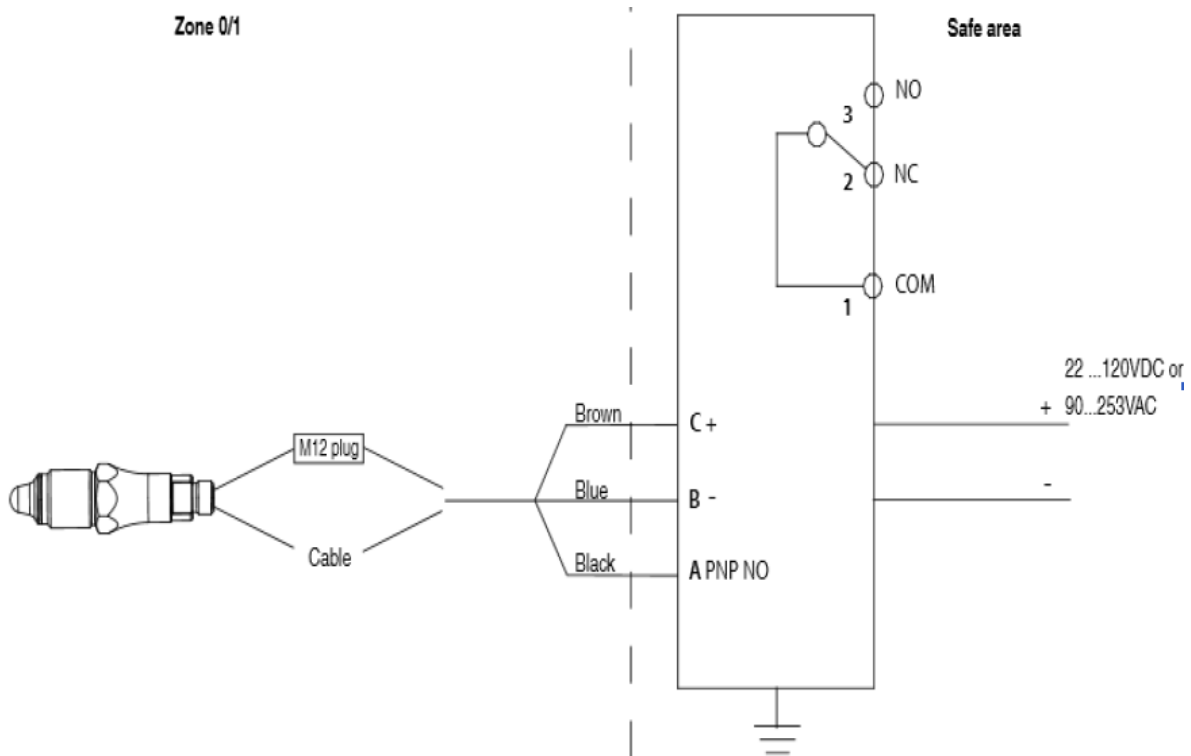

8.7 Relay Outputs of Barrier

SLUGGUARD and barrier are configured to use relay connectors 1 (COM) and 3 (NO).

If you connect as shown in the above scheme this –a missing SLUGGUARD® or a broken cable will create an ALARM to indicate fail safe error.

For the connection of relay output 1 and 3 – internal switch inside the barrier must be set to normal.

Open front cover

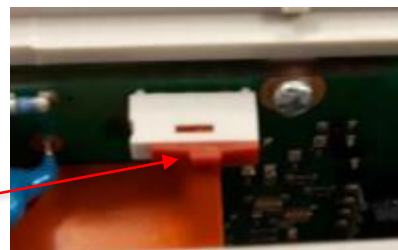

Check switch to sit as shown above:

9. Cleaning, Maintenance and Repair

Cleaning

Cleaning of the SLUGGUARD® is recommended – preferable during quarterly check.

Maintenance

Regular maintenance is not required.

Repair

Do not repair the SLUGGUARD® yourself.
Send the damaged sensor to FAUDI Aviation GmbH.

9.1 Disposal



Do not dispose of in household waste.
Separate materials and dispose of in compliance with nationally applicable regulations.

10. Technical Data

Environmental conditions	
Operating temperature range	▪ -40...+85 °C
Storage temperature range	▪ -40...+85 °C
Ambient humidity	▪ < 98 % RH, condensing
Protection class	▪ IP67 ▪ IP69K (with appropriate cable)
Oscillations (sinusoidal) (EN 60068-2-6)	▪ 1.6 mm p-p (2...25 Hz), 4 g (25...100 Hz), 1 oktave / min.
Power supply	
Voltage supply range	▪ 12...30 V DC
Reverse polarity protection	▪ yes
Current consumption (without load)	▪ 25 mA typ., 50 mA max.
Power-up time	▪ < 2 s
Features	
Repeatability	▪ ± 1 mm
Hysteresis	▪ ± 1 mm
Response time	▪ 0.1 s
Damping	▪ 0.0...10.0 s (configurable)
Output signal	
Output type	▪ PNP ▪ NPN
Current load	▪ 20 mA max.
Short circuit protection	▪ Yes
Voltage drop	▪ PNP: (+Vs -1.5V) ±0.5 V, Rload = 10kΩ ▪ NPN: (+1.5 V) ±0.5 V, Rload = 10kΩ
Leakage current	▪ max. ± 100 µA
Switching logic	▪ Normally open (NO), active low ▪ Normally closed (NC), high enabled

11. ATEX Approval

- Translation**
- (1) **EU-Type Examination Certificate**
- (2) Equipment and protective systems intended for use in potentially explosive atmospheres, **Directive 2014/34/EU**
- (3) **Certificate Number** TÜV 19 ATEX 247467 X **issue:** 00
- (4) for the product: Level Switch type SLUGGUARD
- (5) of the manufacturer: **FAUDI Aviation GmbH**
- (6) **Address:** Scharnhorststrasse 7B
35260 Stadtallendorf
Germany
- Order number: 8003007188
Date of issue: 2020-04-30
- (7) The design of this product and any acceptable variation thereto are specified in the schedule to this EU-Type Examination Certificate and the documents therein referred to.
- (8) The TÜV NORD CERT GmbH, Notified Body No. 0044, in accordance with Article 17 of the Directive 2014/34/EU of the European Parliament and the Council of 26 February 2014, certifies that this product has been found to comply with the Essential Health and Safety Requirements relating to the design and construction of products intended for use in potentially explosive atmospheres given in Annex II to the Directive.
The examination and test results are recorded in the confidential ATEX Assessment Report No. 19 203 247467.
- (9) Compliance with the Essential Health and Safety Requirements has been assured by compliance with:
EN IEC 60079-0:2018 EN 60079-11:2012 EN 60079-31:2014
except in respect of those requirements listed at item 18 of the schedule.
- (10) If the sign "X" is placed after the certificate number, it indicates that the product is subject to the Specific Conditions for Use specified in the schedule to this certificate.
- (11) This EU-Type Examination Certificate relates only to the design, and construction of the specified product. Further requirements of the Directive apply to the manufacturing process and supply of this equipment. These are not covered by this certificate.
- (12) The marking of the product shall include the following:



 **II 1 G Ex Ia IIC T5/T4 Ga or
II 1 D Ex ta IIC T100°C Da**

TÜV NORD CERT GmbH, Langemarckstraße 20, 45141 Essen, notified by the central office of the countries for safety engineering (ZLS), Ident. Nr. 0044, legal successor of the TÜV NORD CERT GmbH & Co. KG Ident. Nr. 0032

The head of the notified body

Röder

Hanover office, Am TÜV 1, 30519 Hannover, Tel. +49 511 998-61455, Fax +49 511 998-61590

This certificate may only be reproduced without any change, schedule included.
Excerpts or changes shall be allowed by the TÜV NORD CERT GmbH



(13) **SCHEDULE**

(14) **EU-Type Examination Certificate No. TÜV 19 ATEX 247467 X** **issue 00**

(15) **Description of product**

The product is used for measuring the level of a fluid or powder media.
The measuring principle is based on the DK value of the media. A signal transmitted from the tip of the sensor is swept from approximately 100 to 180 MHz, and is detected by the capacitance measured from sensor tip to the nearest tank or pipe wall.
An internal inductor in series with the measured capacitance forms resonance circuit. The resonance frequency of this circuit is used to determine if a media is present.
The product contains a PCB mounted with electrical components. This contains the electronic circuit necessary for the products functionality.
The PCB is mounted in a stainless steel housing and sealed in top and bottom to achieve an IP protection degree of IP 67. The shape of the steel housing may vary, but will always fully enclose the PCB and sensor. The connection is done via an M12 plug.
The sensor electrode is encapsulated, and thereby insulated, by the material of PSU or PEEK and has no electrical connection to the media.

Type key
SLUGGUARD

Electrical data

Supply and Signal circuit (Plug M12)	In type of protection intrinsic safety Ex ia IIC Only for connection to certified intrinsically safe circuits. Maximum values:
	$U_i = 30 \text{ VDC}$
	$I_i = 100 \text{ mA}$
	$P_i = 0.75 \text{ W}$
Effective internal capacitance	$C_i = 43 \text{ nF}$
Effective internal inductance	$L_i = 10 \text{ }\mu\text{H}$

Thermal data

Permissible range of ambient temperature: -40 °C up to +74 °C T5
-40 °C up to +85 °C T4 resp. T100°C

(16) Drawings and documents are listed in the ATEX Assessment Report No. 19 203 247467

(17) **Specific Conditions for Use**

1. The dielectric strength test of 500 V r.m.s is not satisfied for the level switch. The maximum insulation voltage between housing and intrinsically safe housing is 40 V. The user must take special care during installation.
2. The sensor can be delivered with factory mounted M12 plug connector. The sensor can alternatively be delivered without the M12 plug connector. In case delivery is without plug connector a connector meeting ingress protection IP 67 must be chosen.

(18) **Essential Health and Safety Requirements**

No additional ones

- End of Certificate -

12. EU Declaration of Conformity



EU-Konformitätserklärung EU Declaration of Conformity Déclaration UE de Conformité

Wir erklären in alleiniger Verantwortung, dass die Produkte, auf die sich diese Erklärung bezieht, die grundlegenden Anforderungen der angegebenen Richtlinie(n) erfüllen und basierend auf den aufgeführten Norm(en) bewertet wurden.

We declare under our sole responsibility that the products to which the present declaration relates comply with the essential requirements of the given directive(s) and have been evaluated on the basis of the listed standard(s).

Nous déclarons sous notre seule responsabilité que les produits auxquels se réfère la présente déclaration sont conformes aux exigences essentielles de la directive/ des directives mentionnée(s) et ont été évalués sur la base de la norme/ des normes listée(s).

Hersteller
Manufacturer
Fabricant

FAUDI Aviation GmbH

Bezeichnung
Description
Description

Füllstandsschalter
Level switch
Commutateur de niveau

Typ(en)
Type(s)
SLUGGUARD®

RoHS-Ausnahmen gemäss Anhang / RoHS exceptions according to annex / RoHS exceptions selon l'annexe: III 6c

Richtlinie(n)
Directive(s)

2014/30/EU, 2011/65/EU

Norm(en)
Standard(s)
Norme(s)

EN 61326-1:2013, EN 50121-3-2:2006, EN 61373:1999
EN 50155:2007, Abs./Sec. 12.2.1 - 12.2.12, 12.2.14

Ort und Datum
Place and date
Lieu et date

Stadtallendorf, 12.08.2020

Unterschrift/Name/Funktion
Signature/name/function
Signature/nom/fonction



FAUDI Aviation GmbH
Schornhorststraße 7B
35260 Stadtallendorf
Telefon (0 64 28) 44 65-2 75
Telefax (0 64 28) 44 65-2 21

Hausanschrift / Address
FAUDI Aviation GmbH
Schornhorststraße 7B
35260 Stadtallendorf
Germany
Handelsregister / Registered
Marburg HRB 5547
USt-ID-Nr. DE 265 479 636

Bankverbindung / Bank account
Sparkasse Marburg Biedenkopf
Konto 63020400, BLZ 633 500 00
IBAN: DE53 5335 0000 0063 0204 00
Swift: HELADEF1MAR

Bankverbindung / Bank account
Commerzbank Giessen
Konto 50 50 455, BLZ 533 400 24
IBAN: DE51 5334 0024 0505 0455 00
Swift: COBADE33XXX

Geschäftsführer / Managing Directors
Marcus Wildschütz
Jürgen Buss
Matthias Aden

Phone: +49 6428 44652 - 570
Fax: +49 6428 44652 - 223
Email: contact@audi-aviation.com
Web: www.faudi-aviation.com